



# Data Sheet WPS-4A



## PPC Weather Protection System

### 1/2" Annular

Designed to provide an additional layer of protection against corrosion caused by prolonged exposure to environmental factors found in the atmosphere such as moisture, salts and abrasive particles.

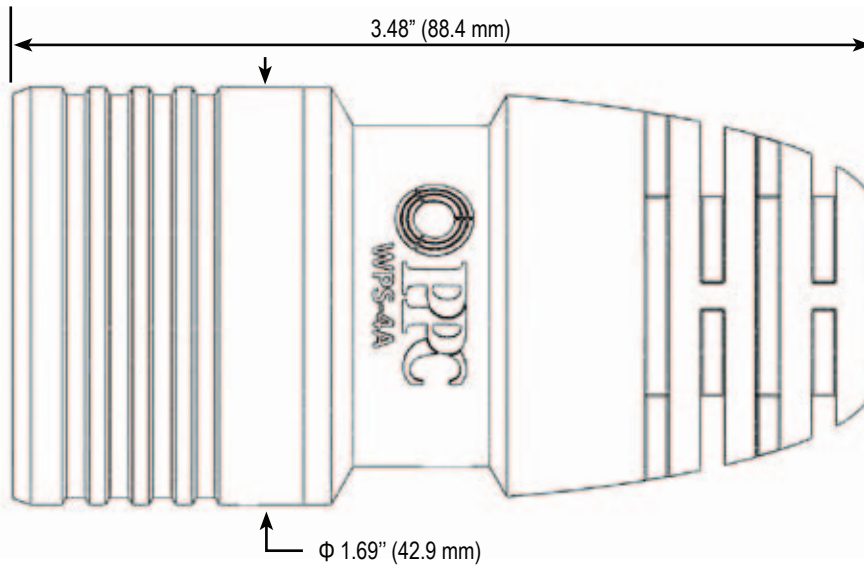

| Environmental            | Specification  | Comment                         |
|--------------------------|--|---------------------------------|
| Installation Temperature | -40°C to + 65° C   |                                 |
| Operating Temperature    | -40°C to + 65° C   |                                 |
| Storage Temperature      | -55°C to + 85° C   |                                 |
| Moisture Resistance      | No Leakage   | ANSI/SCTE 60 2004, IP-67, IP-68 |
| Corrosion Resistance     | 1000 Hours   | ASTM B117                       |
| U.V. Resistance          | Exposure to UV light for 1000 hours per ASTM G 53 using UVB-313 type lamps |                                 |
| H.A.L.T.                 | 40 Hours   |                                 |

| General          | Specification             | Comment                         |
|------------------|---------------------------|---------------------------------|
| Cables Supported | Andrew                    | LDF4-50A, LDF4RN-50A, HL4RP-50A |
|                  | RFS                       | LCF12-50J                       |
|                  | EUPEN                     | EC4-50                          |
|                  | DRAKA                     | RFA 1/2"-50                     |
|                  | LEONI                     | Flexline 1/2" R                 |
|                  | LS                        | LHF 12D                         |
|                  | CommScope                 | FXL540, CR540                   |
| Weight           | .12 lbs   54 g            |                                 |
| Material         | Silicone Rubber           |                                 |
| Lubricant        | Dow Corning Molykote® III |                                 |
| Reusability      | Unlimited                 |                                 |