

# MX06FRO640-02

## NWAV™ X-Pol Hex-Port Antenna

### X-Pol Hex-Port 6 ft 40° Fast Roll Off:

#### 2 ports 698-894 MHz and 4 ports 1695-2180 MHz

- Fast Roll Off (FRO™) azimuth beam pattern improves Intra- and Inter-cell SINR
- Excellent passive intermodulation (PIM) performance reduces harmful interference.
- Fully integrated (iRETs) with independent RET control for low and high bands for ease of network optimization
- SON-Ready array spacing supports beamforming capabilities
- Suitable for LTE/CDMA/PCS/UMTS/GSM air interface technologies
- Integrated Smart Bias-Ts reduce leasing costs

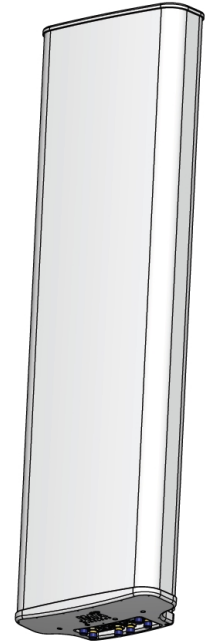

**NWAV™**

#### Fast Roll-Off antennas increase data throughput without compromising coverage

The horizontal beam produced by Fast Roll-Off (FRO) technology increases the Signal to Interference & Noise Ratio (SINR) by eliminating overlap between sectors .

##### Non-FRO antenna

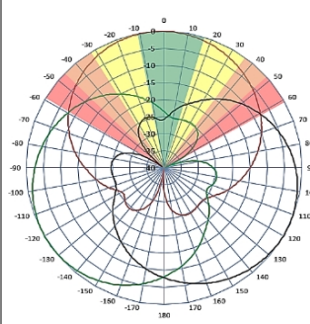

Large traditional antenna pattern overlap creates harmful interference.

JMA's FRO antenna pattern minimizes overlap, thereby minimizing interference.

##### JMA FRO antenna

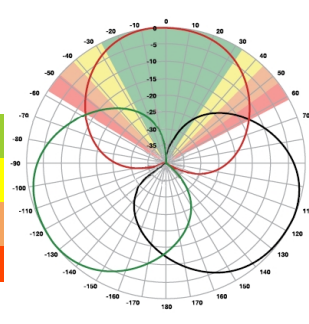

LTE throughput	SINR	Speed (bps/Hz)	Speed increase	CQI
Excellent	>18	>4.5	333+%	8-10
Good	15-18	3.3-4.5	277%	6-7
Fair	10-15	2-3.3	160%	4-6
Poor	<10	<2	0%	1-3

The LTE radio automatically selects the best throughput based on measured SINR.

Electrical specification (minimum/maximum)	Ports 1, 2		Ports 3, 4, 5, 6		
	Frequency bands, MHz	698-798	824-894	1695-1880	1850-1990
Polarization	± 45°		± 45°		
Average gain over all tilts, dBi	16.3	17.2	19.3	20.1	20.4
Horizontal beamwidth (HBW), degrees	42	37	40	39	37
Front-to-back ratio, co-polar power @180°± 30°, dB	>25.0	>25.0	>28.0	>28.0	>28.0
X-Pol discrimination (CPR) at boresight, dB	>18.0	>15.0	>18	>18	>15
Sector power ratio, percent	<4.5	<3.5	<3.7	<3.8	<3.6
Vertical beamwidth (VBW), degrees <sup>1</sup>	13.1	11.8	6.0	5.7	5.3
Electrical downtilt (EDT) range, degrees	2-14	2-14	0-9		
First upper side lobe (USLS) suppression, dB <sup>1</sup>	≤-15.0	≤-15.0	≤-16.0	≤-16.0	≤-16.0
Cross-polar isolation, port-to-port, dB <sup>1</sup>	25	25	25	25	25
Max VSWR / return loss, dB	1.5:1 / -14.0		1.5:1 / -14.0		
Max passive intermodulation (PIM), 2x20W carrier, dBc	-153		-153		
Max input power per any port, watts	300		250		
Total composite power all ports, watts	1500				

<sup>1</sup> Typical value over frequency and tilt

Mechanical specifications	
Dimensions height/width/depth, inches (mm)	72/ 19.8/ 10.7 (1829/ 504/ 271)
Shipping dimensions length/width/height, inches (mm)	84/ 26/ 15 (2134/ 660/ 381)
No. of RF input ports, connector type, and location	6 x 4.3-10 female, bottom
RF connector torque	96 lbf-in (10.85 N·m or 8 lbf-ft)
Net antenna weight, lb (kg)	69 (31.36)
Shipping weight, lb (kg)	109 (49.55)
Antenna mounting and downtilt kit included with antenna	91900318
Net weight of the mounting and downtilt kit, lb (kg)	18 (8.18)
Range of mechanical up/down tilt	-2° to 14°
Rated wind survival speed, mph (km/h)	150 (241)
Frontal, lateral, and rear wind loading @ 150 km/h, lbf (N)	263 (1170), 112 (498), 263 (1170)
Equivalent flat plate @ 100 mph and Cd=2, sq ft	4.06

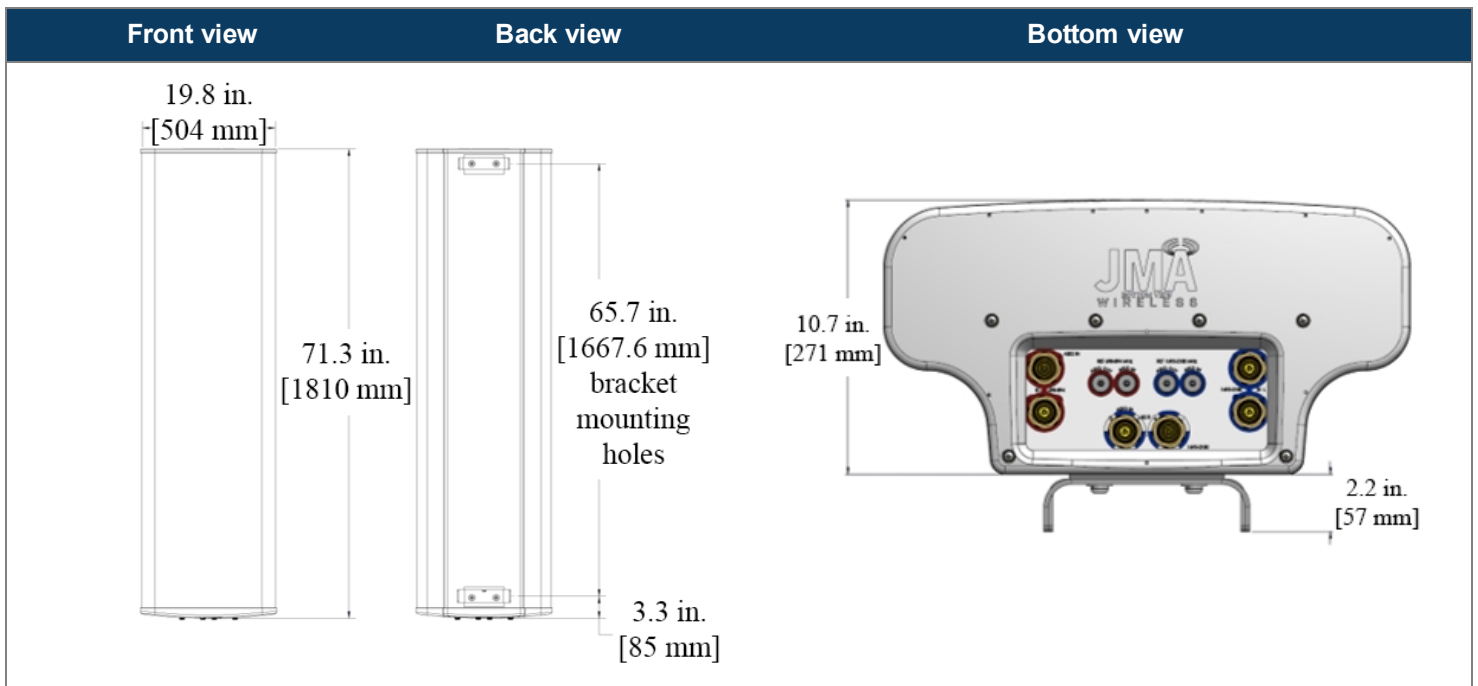

Ordering information	
Antenna model	Description
MX06FRO640-02	6F X-Pol HEX FRO 40°, 2-14° / 0-9° RET, 4.3-10 & SBT
Optional accessories	
<a href="#">AISG cables</a>	M/F cables for AISG connections
<a href="#">PCU-1000 RET controller</a>	Stand-alone controller for RET control and configurations

Remote electrical tilt (RET 1000) information	
RET location	Integrated into antenna
RET interface connector type	8-pin AISG connector per IEC 60130-9
RET connector torque	Min 0.5 N·m to max 1.0 N·m (hand pressure & finger tight)
RET interface connector quantity	2 pairs of AISG male/female connectors
RET interface connector location	Bottom of the antenna
Total no. of internal RETs (low bands)	1
Total no. of internal RETs (high bands)	1
RET input operating voltage, vdc	10-30
RET max power consumption, idle state, W	≤ 2.0
RET max power consumption, normal operating conditions, W	≤ 13.0
RET communication protocol	AISG 2.0 / 3GPP

### RET and RF connector topology

Each RET device can be controlled either via the designated external AISG connector or RF port as shown below:

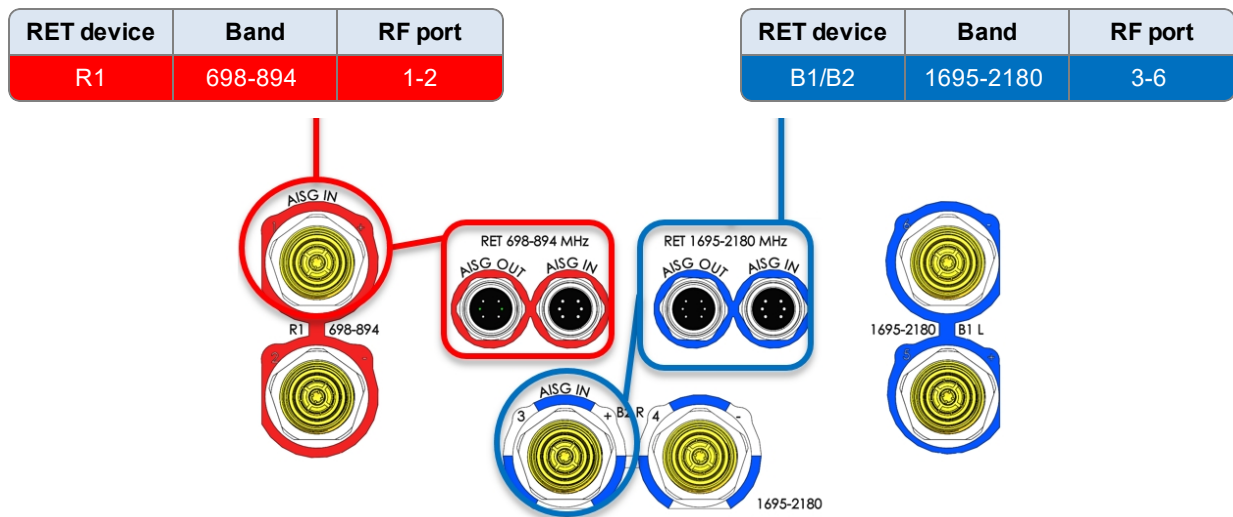

### Array topology

3 sets of radiating arrays R1: 698-894 MHz B1: 1695-2180 MHz B2: 1695-2180 MHz	<table border="1"> <thead> <tr> <th>Band</th> <th>RF port</th> </tr> </thead> <tbody> <tr> <td>1695-2180</td> <td>3-4</td> </tr> <tr> <td>698-894</td> <td>1-2</td> </tr> <tr> <td>1695-2180</td> <td>5-6</td> </tr> </tbody> </table>	Band	RF port	1695-2180	3-4	698-894	1-2	1695-2180	5-6	
	Band	RF port								
1695-2180	3-4									
698-894	1-2									
1695-2180	5-6									